



Features of Structural and Functional Interaction in Calculating the Standard Value of Empty Wagon Flow



Dmitry A. Khodykin

Joint Stock Company «Institute of Transport Economics and Development» (JSC «IERT»), Moscow, Russia.

Russian Science Citation Index SPIN-code: 6650–3920; Russian Science Citation Index AuthorID: 1238098.

✉ xoguk@mail.ru.

Dmitry A. KHODYKIN

ABSTRACT

The objective of the article is to show the possibility of controlling empty wagon flows belonging to different operators using the example of structural and functional relationships. The interaction of the per-flow control of wagons with the systems of operated fleet size regulation can show a possibility of establishing the standards of separate rail wagon dispatch for individual operators in structural schemes. Then with a decrease in the disorganisation of the wagon flow, grows a possibility of redirecting the wagon flow to different loading stations, thus increasing the controllability of the fleet and reducing to zero additional runs from one loading stations to those actually specified in the transport shipping documents.

The study suggests applying scientific approaches when working with limiting points that arise due to the standardisation of the operating parameters of wagon fleets. The proposed approaches, under different operating modes, will lead to a decrease in restraints. The first operating mode: a shortage of wagons, in which the network operates as a channel: the network accepts and processes the entire incoming flow (brings it to loading stations), sometimes there is a shortage of wagons at

loading stations. The second operating mode: the network operates as a sort of buffer storage, the network accepts all wagons for transportation, but is unable to transport them, cargo wagons are accumulated on the network temporarily delaying their transportation through routes. Comprehensive measures are required to stabilise the work with wagon fleets. The third operating mode essentially reflects the use of comprehensive measures. In this mode, the transport network operates in conditions of the influence of excess cargo wagon fleet, while accepting for transportation only the number of wagons that it can transport. Excess wagons, from the point of view of the impact on the public infrastructure, remain on non-public tracks. To operate under introduced limitations, it is proposed to work on reducing the disorganisation of the wagon flow, which, together with per-flow control, will reduce the number of limitations, reduce the load on the carrier's infrastructure. An example shows implementation of the suggested approaches as for applicability of the idea of per-flow wagon control through standardising the changing destination of empty wagons for places of mass loading considering the structural and functional interaction.

Keywords: railway transport, wagon flow, network, channel, buffer storage, transportation of gondola cars.

For citation: Khodykin, D. A. Features of Structural and Functional Interaction in Calculating the Standard Value of Empty Wagon Flow. World of Transport and Transportation, 2024, Vol. 22, Iss. 5 (114), pp. 191–197. DOI: <https://doi.org/10.30932/1992-3252-2024-22-5-9>.

**The original text of the article in Russian is published in the first part of the issue.
Текст статьи на русском языке публикуется в первой части данного выпуска.**

BACKGROUND

Currently, JSC Russian Railways is facing problems that require solutions and may concern limitations: regulation systems, traffic flow control systems [1]. The fragmented arrival of empty wagons at loading stations in conditions of a surplus of wagon fleets complicates their processing en route and especially at terminal stations, as it requires extra track occupancy and shunting operations to select wagons for delivery for loading [2].

The cargo wagon fleet on the network is approaching 1,4 million. The dynamics of production of new wagons significantly outpaces the rate of decommissioning of cargo wagons. During three quarters of 2024 alone, according to wagon manufacturers association, about 54,1 thousand new cargo wagons were produced (more than 72 thousand were awaited by the end of the year), while the decommissioning amounted to 14,2 thousand wagons¹. In turn, the pace of development of the infrastructure capacities of railway transport does not provide the possibility of placing the entire fleet of cargo wagons on the transport network. A situation arises when the placement of the wagon fleet on the current infrastructure leads to a decrease in the network's transit capacity and, as a result, to a decrease in the volume of transportation. A paradox arises – there are more wagons – less transportation. The dynamics of the growth of the wagon fleet will continue until 2027 inclusive.

METHODOLOGICAL SCIENTIFIC APPROACH

There are several types of regulation of wagon fleets, which are shown in Pic. 1.

The article will consider structural and functional regulation, that shows the degree of coordination of the connecting elements.

Structural and functional interaction characterises the interaction of operations within the technological process and the development of flow control.

Search for the optimal solution for management of the wagon fleet in the presence of multiple operators in the transport services market with high competition among actors faces problem of reduced manoeuvring capacity of stations and network segments caused by the

factor of excess cargo wagon fleet and disorganisation of wagon flow (Pic. 2).

In the transport sector, it is possible to distinguish the structural and functional interaction of wagon flows as a special type of interaction, when technological methods change the parameters of the wagon flow structure [3]. Control creates the effect of reserves or backups, dynamic reserves appear, which functionally replace static, actual reserves. Structural and functional is a special type of interaction, when technological methods change the parameters of the structure. The structure seemingly adapts to the current situation, which increases the efficiency of the system. It is possible, with constant aggregate parameters of the channel – buffer storage system, to change the throughput of channels by adjusting the capacity of the buffer storage « [3].

Recently, issues of transportation reliability and reducing the risks of delays in delivery have been actively discussed [4], which means that the study of the issue of functional interaction and the study of the structure of transportation is especially relevant.

The article considers different modes of operation of the transport system with different approaches to accepting wagons for transportation. «The joint work of JSC Russian Railways (hereinafter referred to as the Carrier), Cargo Owners and Operators has made it possible to significantly advance in the development and implementation of various methods, and the current temporary technology of interaction between the Carrier and Operators has expanded the possibilities of redirection, accumulation of train routes, and reduced the risks» [3] of failure to provide cargo owners with rolling stock.

The structural and functional interaction can be present in different modes of operation of the transport system. The first operating mode: «shortage of gondola cars, the network operates as a channel (Pic. 3), non-public railway tracks (in the picture – NPR) accept wagons, unload them and send them. All wagons participate in transportation; there are no restrictions on the clearance of wagons» [5]. With this scheme, the entire empty wagon flow after unloading on NPR with disorganisation ρ_{in1} is accepted for transportation with input disorganisation ρ_{in2} . The network operates as a channel; there are no restrictions on transit capacity. The entire wagon flow passes the channel, the wagon flow is subject to channel noise $\Delta\rho_2$ and the wagon flow with disorganisation ρ_{out2} gets onto NPR, then with

¹ Association of wagon manufacturers, Report for three quarters 2024. [Electronic resource]: <https://clck.ru/3TvvTR> (in Russian).

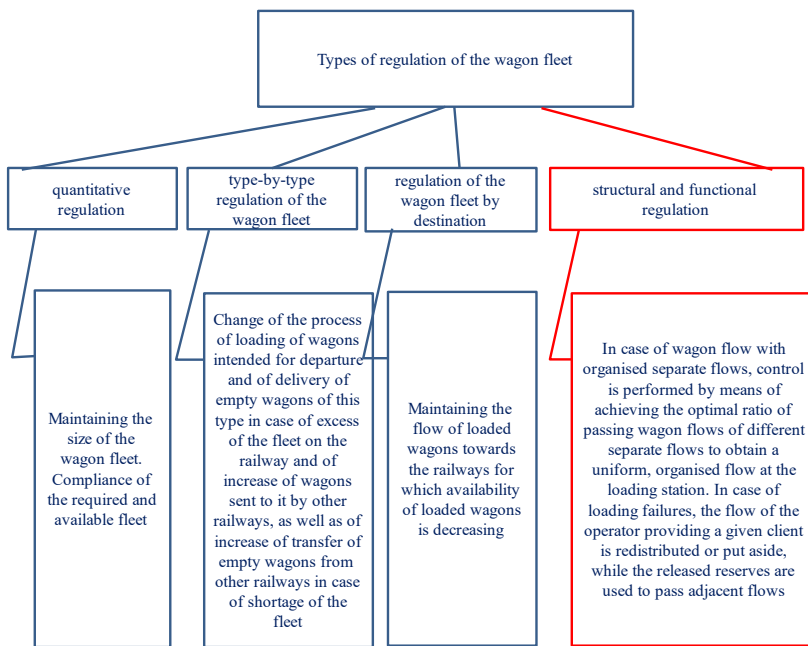

Pic 1. Types of regulation of wagon fleets [performed by the author].

The reliability of the transport system can be ensured in two ways:

- large reserves at the starting and ending points with underdeveloped management
- small reserves with developed management.



Pic 2. Disorganised and organised wagon flow [performed by the author].

disorganisation p_{out3} wagons are loaded. There is no mass accumulation of wagons through the entire stage of the transportation process. The wagons arrive to be loaded and are in demand [3].

The second operating mode: the network operates as a buffer storage (or bunker) (see Pic. 4), using the capabilities of dynamic resources. Several scenarios of the network operating as a buffer storage are possible: the network accepts all wagons for transportation but is no longer able to transport them; an excess number of wagons accumulates on the infrastructure in trains temporarily suspended from service (the network has operated as

a buffer storage) [3].

«Gradually, we came to the conclusion that the network is not capable of accepting an infinite number of empty gondola cars for transportation» and that rules for operating during a period of gondola car surplus are needed. «The third operating mode: the transport market operates under conditions of surplus, loading and unloading stations operate as buffer storages, and the network operates as a channel. In this operating mode, limitations on the clearance of empty wagons are necessary» [3]. Pic. 5 shows the points of application of limitations when the carrier regulates which empty gondola cars after



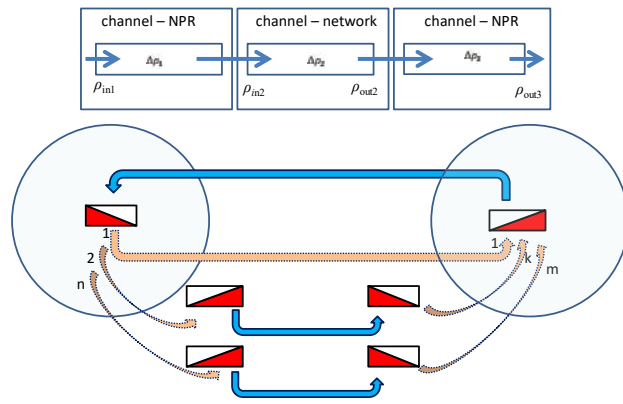

Pic. 3. Unlimited operating mode, the network operates as a channel [performed by the author].

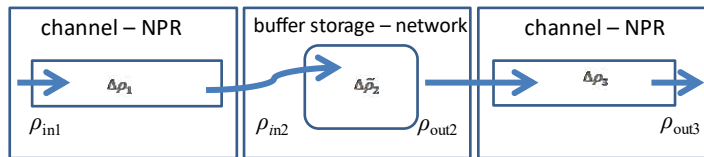

Pic. 4. Network operates as a buffer storage [performed by the author].

unloading it can accept for transportation and which it cannot. It turns out that according to a certain algorithm, which must comply with the Charter of Railway Transport, the carrier at the unloading stations (1, 2, ..., n) determines the number of wagons that it can accept for transportation [3].

Then the shown structural and functional chart will designate the operation of the network as a channel that receives wagon traffic from non-public railway tracks with some disorganisation ρ_{in2} , the network itself operates as a channel (imposing a certain noise of the channel) and produces at the output (supplies to the loading stations) wagon traffic with disorganisation ρ_{out3} . In this case, a certain quantity of wagons is formed, which the wagon owner distributes for transporting way cargo or which the carrier, in accordance with Article 44 of the Charter of Railway Transport, moves to the transfer stations (see Pic. 6).

In this case, when the excess fleet [7; 10] is sent to transfer stations, the network operates as a channel, the non-public railway tracks at unloading stations also do not accumulate wagons but operate as a channel, and at loading stations there is a reserve of wagons, that is, the non-public railway tracks of loading stations operate as a buffer storage.

Now it is possible to imagine how the network can operate using dynamic reserves, and how it can guarantee the provision of loading resources to shippers. Pic. 7 shows a diagram when the wagon flow is formed for each operator (eliminating the disorganisation of the wagon flow) [10–12]. The entire wagon flow with disorganisation ρ_{in2} enters the network, while empty wagon flows of large operators are allocated to separate flows at marshalling stations according to appurtenance to an operator. These allocated flows can be regulated by changing the power or speed of the flow, thus using dynamic reserves, setting different priorities for passing different operators' wagon flows. A formed operator's flow can be redirected for loading to another station or loading railway. In this way, it becomes possible to control the process, whereas the mixed empty wagon flow with great disorganisation, when it arrives at one of the loading stations, must be sorted and it must be determined which wagons «go further» according to the original shipping documents.

Such an approach is very important for controlling wagon flows, especially in the modern realities of railway transport management [13–20], including empty wagon flows, when the actual distribution is carried out by operators. The possibility of flow control will allow high-quality

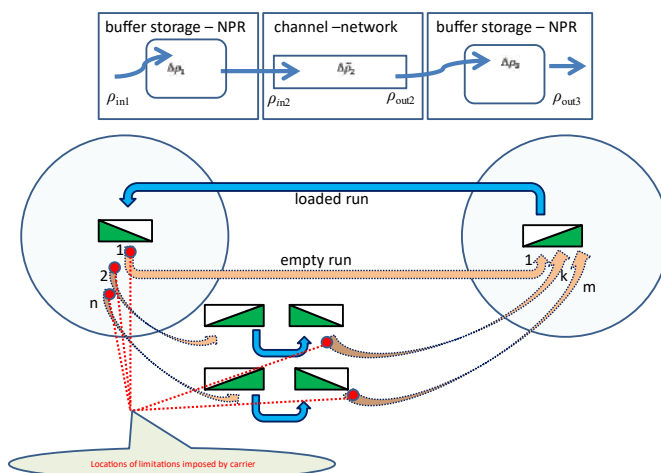

Pic. 5. Points of limitations imposed by carrier when accepting empty gondola cars for transportation [performed by the author].

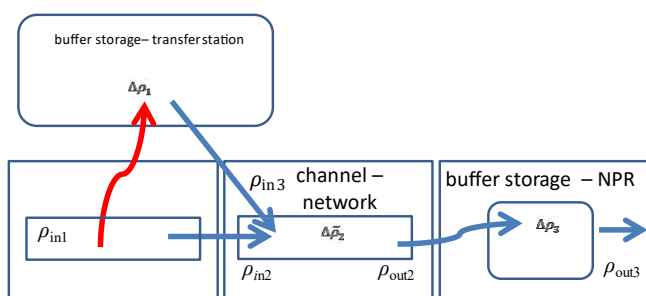

Pic. 6. Excess fleet is sent to the transfer stations [performed by the author].

planning of train distribution considering the current limitations. Pic. 7 shows the interaction of separate wagon flows and the relationship using structural and functional connections.

Conclusion on the scientific methodological approach

Overcoming the crisis caused by excess wagon fleet and disorganisation of wagon flows requires a transition to active structural and functional control. The introduction of a system for regulation the acceptance of empty wagons based on an analysis of network operating modes («channel» / «buffer storage») and controlling structured wagon flows (using dynamic reserves) is a scientifically sound and practically feasible way to improve the efficiency of railway infrastructure operation, increase network capacity and, ultimately, increase the volume of transportation of JSC Russian Railways. Success depends on the coordinated interaction of JSC Russian Railways, operators and cargo owners within the framework of developed methods and regulations.

IMPLEMENTATION

When calculating the standard value for the empty wagon flow, it is necessary to consider the daily loading and the time of movement of empty wagons [15]. Now we will determine the necessary standardisation parameters:

1) Wagon loading rate. Average daily number of requests of form GU-12 [*application for cargo transportation*] from loading stations.

2) Wagon unloading rate. Average daily number of requests for transporting wagons to the railway where they will be subsequently loaded.

3) The rate of accepting empty gondola cars at inter-railway junction points. This is the difference between the rate for loading gondola cars and the rate for unloading wagons within the boundaries of a railway.

4) Standard time for transporting an empty wagon along the route based on the data of previous month of loading.

5) Rate for delivery of empty gondola cars at inter-railway junction points.



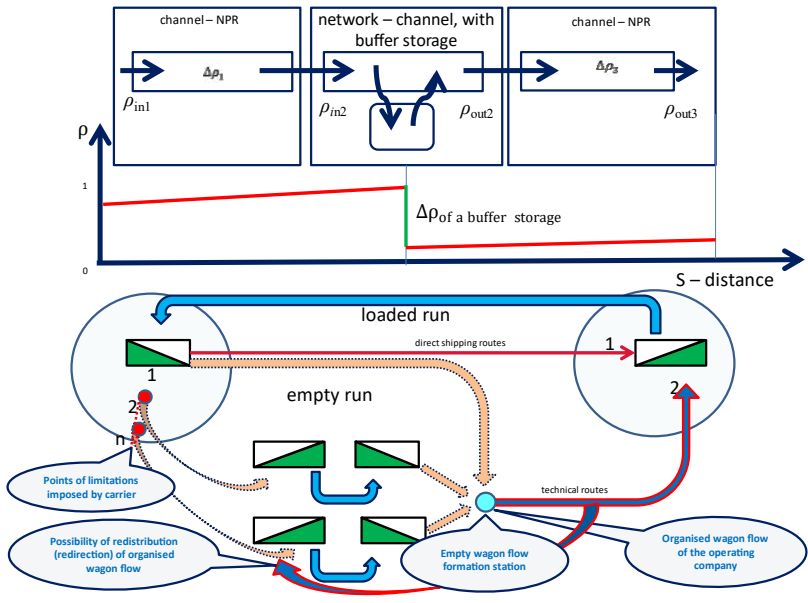

Pic. 7. Applying dynamic reserves [performed by the author].

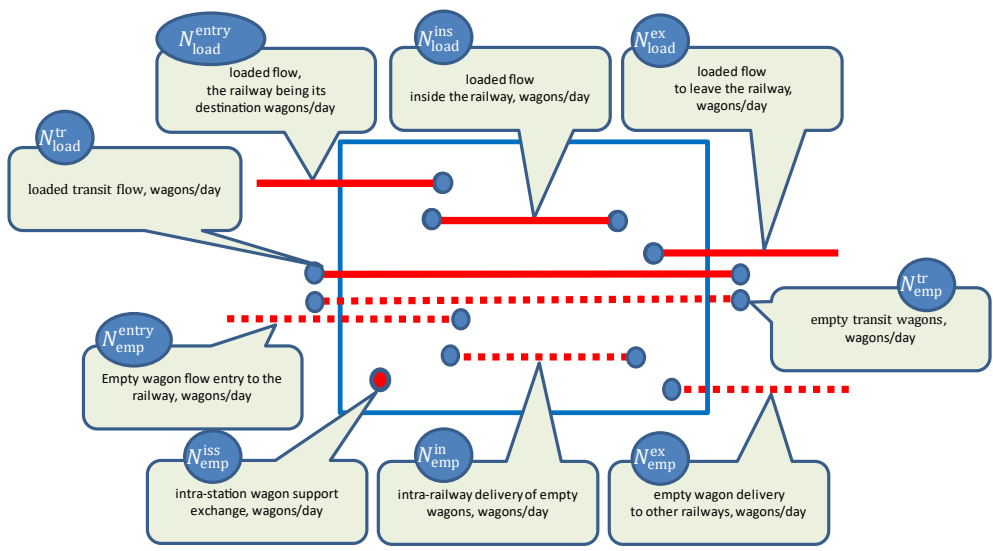

Pic. 8. The structure of standardisation of separate wagon flows [performed by the author].

6) Rate for the fleet of gondola cars per operators. It is obtained by multiplying the turnover of an empty wagon within the boundaries of the railway and the rate for loading gondola cars.

7) Rate for the run of empty gondola cars. It is obtained by multiplying the rate for the acceptance of gondola cars at inter-railway junction points and the rate for the run time along transit railways to inter-railway junction points.

8) The rate for the transporting empty gondola cars from the railways. It is equal to the rate for the acceptance of empty gondola cars, considering the redirection of the wagon flow (en route) for way cargo transportation (according to the temporary regulations for the interaction of operators and JSC Russian Railways).

Pic. 8 shows schematically all types of origin – destination runs that are involved in standardisation.

CONCLUSION

Interaction of operators with carriers in different operating modes of the transport network can be represented using structural and functional interaction and use tools to reduce the disorganisation of empty wagon flows during transportation of bulk cargo, which will lead to a decrease in points of limitations and will allow a smaller number of wagons to ensure the fulfilment of specified volumes of transportation.

REFERENCES

1. Kozlov, P. A. Information technologies on transport. Modern stage [Informatsionnie tekhnologii na transporte. Sovremenniy etap]. *Transport Rossiiskoi Federatsii*, 2007, Iss. 10 (10), pp. 38–41. EDN: JWYILP.
2. Khodykin, D. A. Stream control of cars supply for loading [Postruinoe upravlenie podachei vagonov pod pogruzku]. *Zheleznodorozhnyi transport*, 2015, Iss. 7, pp. 39. EDN: UDLPDH.
3. Khodykin, D. A. Features of structural and functional interaction in calculating the standard value of empty car flow assigned to the West Siberian Railway [Osobennosti strukturno-funktsionalnogo vzaimodeistviya pri raschete normy velichiny porozhnogo vagonopotoka naznacheniem na Zapadno-Sibirskuyu zh.d.]. *Collection of conference papers*. Moscow, CJSC «Universitetskaya kniga», 2023, pp. 208–211. EDN: RQHXIZ.
4. Glazkov, M. O., Borodin, A. F., Maksimova, E. S., Volokitina, I. O. Reducing the risks of delays in delivery of goods and empty cars [Snizhenie riskov narusheniya srokov dostavki грузов i porozhnykh vagonov]. *Zheleznodorozhnyi transport*, 2023, Iss. 11, pp. 6–12. EDN: SKJSBZ.
5. Khodykin, D. A. Impact of Car Flow Disorganization on Car Fleet Management Methods. *World of Transport and Transportation*, 2015, Vol. 13, Iss. 2 (57), pp. 166–175. EDN: UHOIAZ.
6. Khodykin, D. A. Restrictions on the design of cars as a tool for increasing demand for rolling stock services [Ogranicheniya oformleniya vagonov, kak instrument povysheniya sprosna na usluzhi po predostavleniyu podvizhnogo sostava]. *Proceedings of the international scientific and practical conference «Digital technologies of transport and logistics»*. Moscow: RUT (MIIT), 2022, pp. 105–108. EDN: NUSHEB [reference to the collection].
7. Khodykin, D. A. The procedure for determining the excess fleet of freight cars by operators and within the boundaries of roads. *Railway economy*, 2024, Iss. 9, pp. 21–33. [Electronic resource]: <https://railways.prometej.su/annot.php?pdf=/annotations/2024-9/2.pdf>. Last accessed 18.10.2024.
8. Vladimirskaia, I. P. Optimization of structural and functional interaction in transport and production and transport systems. D.Sc. (Eng) thesis [Optimizatsiya strukturno-funktsionalnogo vzaimodeistviya v transportnykh i proizvodstvenno-transportnykh sistemakh. Diss...dok.tekh.nauk]. Moscow, MGUPS (MIIT) publ., 2011, 273 p.
9. Khodykin, D. A. Possibilities of carrier influence on the cost of car provision service by using dynamic reserves of the second kind [Vozmozhnosti vliyaniya perevozhchika na stoimost usluzhi predostavleniya vagonov za schet ispolzovaniya dinamicheskikh rezervov vtorogo roda].

Transport: logistics, construction, operation, management. Collection of works of the International scientific and practical conference, Yekaterinburg, 2023, Iss. 7 (255), pp. 198–200. EDN: BKPTSJ.

10. Borodin, A. F., Khodykin, D. A., Kravchenko, A. A., Nikolaev, K. Yu., Rybakov, S. V., Zhuravleva, E. A., Volokitina, I. O. Assessing the impact of excess freight car fleet on the production indicators of JSC Russian Railways [Otsenka vliyaniya izbytochnogo parka gruzovykh vagonov na proizvodstvennye pokazateli OAO RZD]. *Bulletin uchenogo soveta AO «IERT»*, 2024, Iss. 10–2, pp. 32–49.

11. Khodykin, D. A. Changing the cost of providing gondola cars due to the use of dynamic reserves of the second kind [Izmenenie stoimosti predostavleniya poluvagonov za schet ispolzovaniya dinamicheskikh rezervov vtorogo roda]. *Kochnevsky readings – 2023: modern theory and practice of operational work of railways. Proceedings of II International scientific and practical conference*. Moscow, 2023, pp. 494–497. EDN: EEARRY [reference to the collection].

12. Kolesnikova, E. S. Selection of a rational technology for organizing two-group trains on a route with three support stations [Vybor ratsionalnoi tekhnologii organizatsii dvukhgruppykh poezdov na napravlenii s tremya opornymi stantsiyami]. *Soiskatel – supplement to the journal «World of Transport and Transportation»*, 2005, Iss. 1, pp. 66–77.

13. Kolesnikova, E. S., Ryzhenkov, A. V. Methods for accelerating the movement of car flows [Metody uskoreniya prodvizheniya vagonopotokov]. *Soiskatel – supplement to the journal «World of Transport and Transportation»*, 2010, Iss. 2 (08), pp. 42–44.

14. Prokofieva, E. S., Panin, V. V., Dmitriev, E. O. Technological interaction of participants in the transportation process when organizing transportation [Tekhnologicheskoe vzaimodeistvie uchastnikov perevozhchnogo protsessa pru organizatsii perevozok]. *Transport planning and modeling. Collection of works of V International scientific and practical online conference*. Moscow, RUT (MIIT) publ., 2020, pp. 138–141. EDN: EXRJNJ.

15. Saibatalov, R. F. Methods for eliminating difficulties in the operation of railway network polygons. Pg.D. (Eng) thesis [Metody ustraneniya zatrudnenii v rabote poligonov zheleznodorozhnoi seti. Diss...kand.tekh.nauk]. Yekaterinburg, USURT publ., 2021, 231 p. EDN: QHULCB.

16. Bergard, K. A. Technical routing of railway transportation [Tekhnicheskaya marshrutizatsiya zheleznodorozhnykh perevozok]. Moscow, Transzheldorizdat publ., 1957, 237 p.

17. Kobzev, S. A. On the priorities in the innovative activities of JSC Russian Railways [O prioritetakh v innovatsionnoi deyatel'nosti OAO RZD]. *Zheleznodorozhnyi transport*, 2019, Iss. 2, pp. 29–36. EDN: MKZIJF.

18. Saibatalov, R. F., Borodin, A. F. Car fleet, infrastructure and traffic management – to a common denominator [Vagonnyi transport, infrastrukturu i upravlenie dvizheniem k obshchemu znamenatelyu]. *Zheleznodorozhnyi transport*, 2014, Iss. 11, pp. 26–34. EDN SYKXOP.

19. Saibatalov, R. F. Key tasks of transition to planning and organizing traffic at polygons [Klyucheve zadachi perekhoda k planirovaniyu i organizatsii dvizheniya na poligonakh]. *Zheleznodorozhnyi transport*, 2016, Iss. 6, pp. 32–37. EDN: WEALYN.

20. Rakhimzhanov, D. M. By building a through process of transportation [Vystraivaya skvoznoi protsess perevozhchnoi deyatel'nosti]. *Zheleznodorozhnyi transport*, 2020, Iss. 5, pp. 16–19. EDN: RTAEXC. ●

Information about the author:

Khodykin, Dmitry A., Expert of the Department of Transport Infrastructure Project Management of Joint Stock Company «Institute of Transport Economics and Development» (JSC «IERT»), Moscow, Russia, xoguk@mail.ru.

Article received 03.05.2024, approved after reviewing 27.10.2024, accepted 06.11.2024.

